



Datasheet

FREEDOM *SELECT*

High accuracy 6-axis portable arm for touch probe metrology

Go-to metrology and multi-functional capability

- Probing accuracy certified to ISO 10360-12
- Wireless connection and battery operation capability
- Effortless infinite rotation and unique Zero-G counterbalance
- Simply turn on and start measuring, no encoder referencing
- Convenient LED wrist display and multi-functional buttons
- Hot-swap probes without probe recalibration
- Carbon-fibre construction for long term stability

FREEDOM arm package:

- SELECT portable arm
- rotating spin-grip and spin-knob
- interface software RDS
- base plate mounting ring
- protective dust cover
- storage and transit case
- portable arm power supply
- calibration sphere with ISO17025 certificate
- verification bar with ISO17025 certificate
- accuracy verification with ISO10360-12 certificate for tactile measurement
- 12 months manufacturers standard warranty
- wired control pack CP-C includes
 - cable ODU-Ethernet 3m (9.8 feet)
 - adapter USB-Ethernet
- accessory kit includes:
 - diam. 15mm x 50mm probe
 - diam. 5mm x 50mm probe
 - diam. 3mm x 50mm probe
 - accessory case



...we are metrology

TECHNICAL DATA | Dimensions and Weights

FREEDOM SELECT

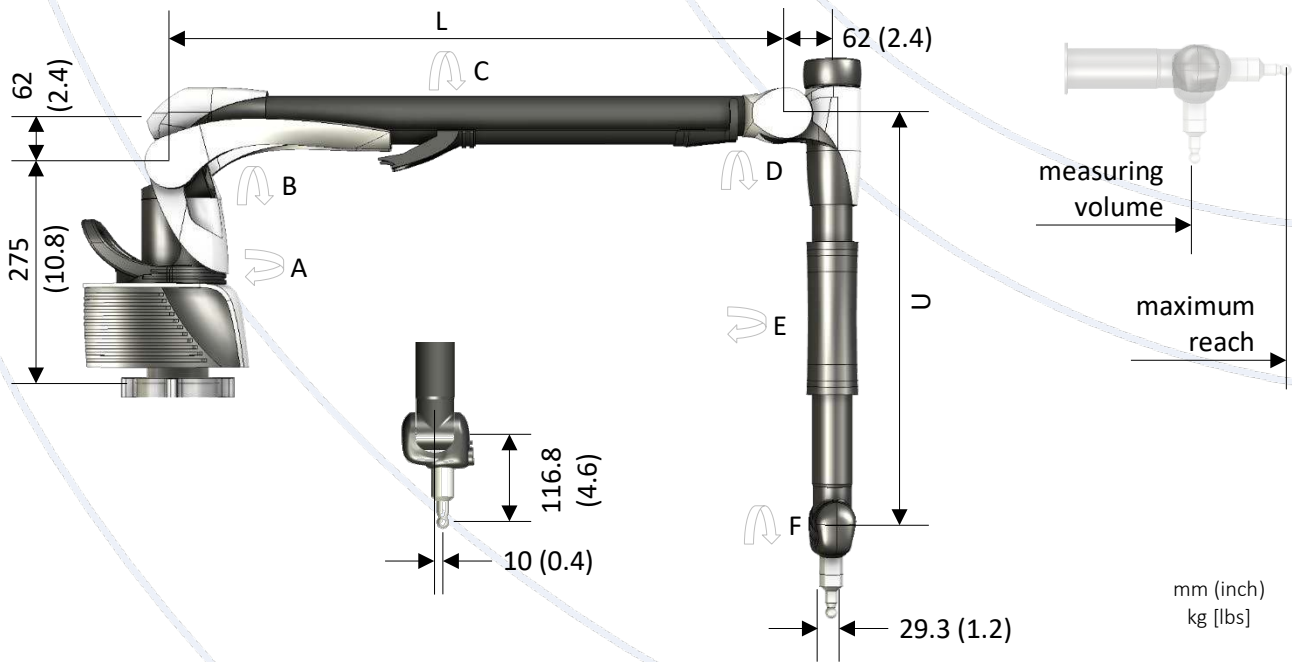

mm (inch)
kg [lbs]

	VOLUME ¹	REACH ¹	AXIS ROTATION ²						SECTIONS		WEIGHT
			A	B	C	D	E	F	L	U	
FREEDOM SELECT 20	2000 (78.7)	2230 (87.8)	∞	-0.94 +1.42	∞	-1.35 +1.22	∞	-1.71 +1.71	600 (23.6)	400 (15.7)	8.0 [17.6]
FREEDOM SELECT 25	2500 (98.4)	2730 (107.5)	∞	-0.94 +1.42	∞	-1.35 +1.22	∞	-1.71 +1.71	750 (29.5)	500 (19.7)	8.3 [18.3]
FREEDOM SELECT 30	3000 (118.1)	3230 (127.2)	∞	-0.94 +1.42	∞	-1.35 +1.22	∞	-1.71 +1.71	900 (35.4)	600 (23.6)	8.6 [19.0]
FREEDOM SELECT 35	3500 (137.8)	3730 (146.9)	∞	-0.94 +1.42	∞	-1.35 +1.22	∞	-1.71 +1.71	1050 (41.3)	700 (27.6)	8.9 [19.6]
FREEDOM SELECT 40	4000 (157.5)	4230 (166.5)	∞	-0.94 +1.42	∞	-1.35 +1.22	∞	-1.71 +1.71	1200 (47.2)	800 (31.5)	9.2 [20.3]
FREEDOM SELECT 45	4500 (177.2)	4730 (186.2)	∞	-0.94 +1.42	∞	-1.35 +1.22	∞	-1.71 +1.71	1350 (53.1)	900 (35.4)	9.5 [20.9]

¹Measuring Volume and Maximum Reach specified as a spherical diameter using 50mm long probe.

²Axis Rotation angles measured in Radians.

TECHNICAL DATA | Accuracy

FREEDOM SELECT

The FREEDOM arm is delivered fully traceable to internationally recognised accuracy certification ISO 10360-12 for probing accuracy, giving users complete confidence in the reliability of their measurements.

	TOUCH PROBE ⁴			
	LENGTH E UNI	SIZE P SIZE	POSITION L DIA	FORM P FORM
FREEDOM SELECT 20	0.023 (0.0009)	0.008 (0.0003)	0.030 (0.0012)	0.017 (0.0007)
FREEDOM SELECT 25	0.028 (0.0011)	0.010 (0.0004)	0.035 (0.0014)	0.020 (0.0008)
FREEDOM SELECT 30	0.042 (0.0017)	0.015 (0.0006)	0.053 (0.0021)	0.030 (0.0012)
FREEDOM SELECT 35	0.055 (0.0022)	0.020 (0.0008)	0.069 (0.0027)	0.040 (0.0016)
FREEDOM SELECT 40	0.067 (0.0026)	0.024 (0.0009)	0.085 (0.0033)	0.045 (0.0018)
FREEDOM SELECT 45	0.080 (0.0031)	0.028 (0.0011)	0.102 (0.0040)	0.050 (0.0020)

FREEDOM arm accuracy specifications applicable only when the arm is mounted on the standard base plate mounting ring or optional base magnetic fixing with mounting ring with stable environmental conditions - accuracy is not guaranteed with all other stands and volume extension products.

⁴ Touch probe accuracy specification - applicable only when using the probes supplied in the standard accessory kit.

- E UNI Maximum permissible longitudinal error of measurement according to ISO 10360-12:2016
- P SIZE Maximum permissible probe deviation of size according to ISO 10360-12:2016.
- L DIA Maximum permissible probe deviation of position according to ISO 10360-12:2016
- P FORM Maximum permissible probe deviation of shape according to ISO 10360-12:2016



Distance measurement calculated using 105 length measurements over the volume of the measuring arm using two spheres.



Feature measurement calculated as the difference between the calibrated sphere diameter and 25 point measured sphere diameter.



Repeatability of a sphere position when measured using 5 different arm orientations and repeated for two sphere positions.



Total variation of 25 measured points compared to the diameter of the least squares sphere, worst value from two sphere positions.

TECHNICAL DATA | Control Pack

The connection capabilities and power supply options of the FREEDOM arm are defined by the Control Pack. The CP-C Control Pack, for wired connectivity and mains power, is supplied as standard with every arm. For wireless connectivity, battery power and battery hot-swapping, the CP-W Control Pack is available as an optional extra. CP-W provides up to 4 hours continuous battery power before recharging or hot swapping the battery. Battery hot-swapping allows one of the two rechargeable batteries to be removed, for charging or replacement by a charged battery, while the arm continues to operate on battery power.



CONTROL PACK	CONNECTION			POWER	
	Ethernet cable	USB* cable	wireless	mains	battery
CP-C	✓	✓	-	✓	-
CP-W	✓	✓	✓	✓	✓

*USB connection via included USB to Ethernet cable adapter.



TECHNICAL DATA | Touch Probes

The FREEDOM arm is supplied as standard with a basic probe accessory kit, other probes sizes and configurations are available.

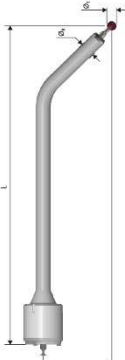
	0085535	aluminium 50mm (1.97") pointed tip M3 tungsten carbide
	0085536	aluminium 75mm (2.95") pointed tip M3 tungsten carbide
	0085537	aluminium 100mm (3.94") pointed tip M3 tungsten carbide
	0085538	aluminium 50mm (1.97") diam. 3mm (0.12") ruby tip M3
	0085539	aluminium 75mm (2.95") diam. 3mm (0.12") ruby tip M3
	0085540	aluminium 100mm (3.94") diam. 3mm (0.12") ruby tip M3
	0085541	aluminium 50mm (1.97") diam. 6mm (0.24") ruby tip M3
	0085542	aluminium 75mm (2.95") diam. 6mm (0.24") ruby tip M3
	0085543	aluminium 100mm (3.94") diam. 6mm (0.24") ruby tip M3
	0085544	carbon fibre 85mm (3.35") pointed tip M3 tungsten carbide
	0085545	carbon fibre 100mm (3.94") pointed tip M3 tungsten carbide
	0085546	carbon fibre 130mm (5.12") pointed tip M3 tungsten carbide
	0085547	carbon fibre 150mm (5.91") pointed tip M3 tungsten carbide
	0085548	carbon fibre 180mm (7.09") pointed tip M3 tungsten carbide
	0085549	carbon fibre 200mm (7.87") pointed tip M3 tungsten carbide
	0085550	carbon fibre 85mm (3.35") diam. 3mm (0.12") ruby tip M3
	0085551	carbon fibre 100mm (3.94") diam. 3mm (0.12") ruby tip M3
	0085552	carbon fibre 130mm (5.12") diam. 3mm (0.12") ruby tip M3
	0085553	carbon fibre 150mm (5.91") diam. 3mm (0.12") ruby tip M3
	0085554	carbon fibre 180mm (7.09") diam. 3mm (0.12") ruby tip M3
	0085555	carbon fibre 200mm (7.87") diam. 3mm (0.12") ruby tip M3
	0085556	carbon fibre 85mm (3.35") diam. 6mm (0.24") ruby tip M3
	0085557	carbon fibre 100mm (3.94") diam. 6mm (0.24") ruby tip M3
	0085558	carbon fibre 130mm (5.12") diam. 6mm (0.24") ruby tip M3
	0085559	carbon fibre 150mm (5.91") diam. 6mm (0.24") ruby tip M3
	0085560	carbon fibre 180mm (7.09") diam. 6mm (0.24") ruby tip M3
	0085561	carbon fibre 200mm (7.87") diam. 6mm (0.24") ruby tip M3
	0085562	aluminium 45° offset 149x38mm (5.87x1.50") pointed tip M3 tungsten carbide
	0085563	aluminium 45° offset 149x38mm (5.87x1.50") diam. 3mm (0.12") ruby tip M3
	0085564	aluminium 45° offset 149x38mm (5.87x1.50") diam. 4mm (0.16") ruby tip M3
	0085565	aluminium 45° offset 149x38mm (5.87x1.50") diam. 6mm (0.24") ruby tip M3
	0085566	aluminium 60° offset 149x57mm (5.87x2.24") pointed tip M3 tungsten carbide
0085567	aluminium 60° offset 149x57mm (5.87x2.24") diam. 3mm (0.12") ruby tip M3	
0085568	aluminium 60° offset 149x57mm (5.87x2.24") diam. 4mm (0.16") ruby tip M3	
0085569	aluminium 60° offset 149x57mm (5.87x2.24") diam. 6mm (0.24") ruby tip M3	
0085570	aluminium 90° offset 173x43mm (6.81x1.69") pointed tip M3 tungsten carbide	
0085571	aluminium 90° offset 173x43mm (6.81x1.69") diam. 3mm (0.12") ruby tip M3	
0085572	aluminium 90° offset 173x43mm (6.81x1.69") diam. 4mm (0.16") ruby tip M3	
0085573	aluminium 90° offset 173x43mm (6.81x1.69") diam. 6mm (0.24") ruby tip M3	

TECHNICAL DATA | Requirements

ENVIRONMENT

Operating temperature	+5°C to +40°C
Storage temperature	-30°C to +70°C
Operating elevation	up to 2000m
Relative humidity	10% to 90% non-condensing

SUPPLY

Power supply	110-240V single phase
--------------	-----------------------

CONFORMITY

Freedom Arm	Probing accuracy certified according to ISO 10360-12 CE – FCC – IC
-------------	---